



PRESSES

MECHANICAL • HYDRAULIC • SERVO

**DOUBLE CRANK
GAP FRAME MECHANICAL PRESSES**

G2 SERIES

110T - 315T



Safeties conform to:
CE (EN-16092 : 2018)
OSHA 1910.217
CSA-Z142

ISO 9001:2015

High Performance Sheet Metal Working

Rigidity • Precision • Reliability



ISGEC RHINO-DOUBLE CRANK GAP FRAME PRESSES

RIGIDITY • PRECISION • RELIABILITY

Rigidity

- Frame fabricated from tested steel plates and stress relieved to ensure uniform stress distribution, better stability and fatigue free long life of the frame.
- Finite Element Analysis software used to verify fatigue life of stress relieved Press structure and to enable maximum rigidity.
- Stronger and symmetric frame having 10% less stress with reinforcement on both sides.
- High rigidity of frame reduces angular deflection thereby maintaining alignment of top and bottom dies. It increases die life and produces better quality stamped parts.

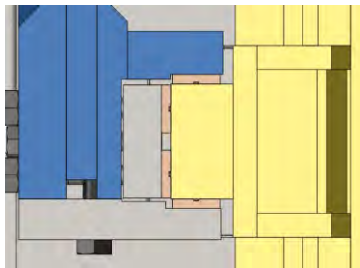
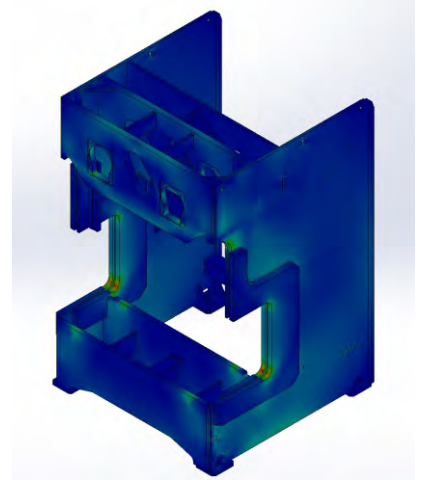

Accurate Slide & Guide

- Extra long six point guides to ensure accurate slide guiding.
- Non Ferrous Liners.
- Accurately machined on CNC Machines.

Precise and Vibration Free Transmission

Crank Shaft

Forged from Normalized Alloy Carbon Steel, Ultrasonically Tested.

CAD analysis ensures elimination of stress concentrations and metal fatigues.

Gear

Gears of drive train machined to precision grade, conforming to DIN Grade 7 or AGMA 10 and better, for smooth torque transmission and vibration free operation.

Pinion

Forged Alloy Steel, Hardened & Tempered, Ultrasonically Tested, Accurately Machined and Ground.

Connecting Rod

Steel Casted, Normalized and Ultrasonically Tested.

Flywheel

Dynamically balanced Flywheel for long life of bearings.

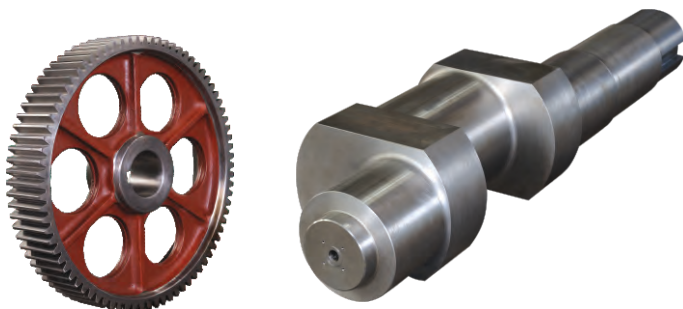

High Work Energy

- Highest Available Work Energy in its Class per Stroke

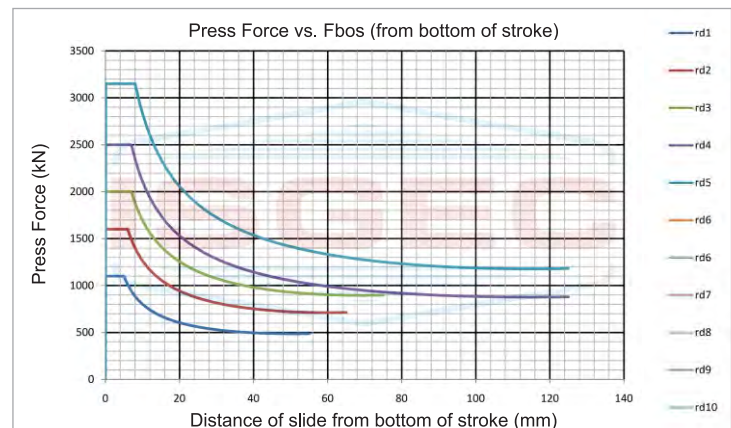

Pneumatic Clutch and Brake

- Pneumatically operated Clutch and Brake for easy maintenance and service.
- Clutch & Brake controlled by Dual Solenoid Valve.
- **Wet Clutch provided on demand.**



ISGEC RHINO-DOUBLE CRANK GAP FRAME PRESSES

RIGIDITY • PRECISION • RELIABILITY



FEATURES

Hydraulic Overload Protection

Hydraulically operated fast acting Over Load protection mechanism mounted on slide for better performance thereby preventing damage to the Press and Dies

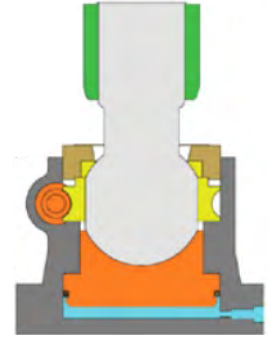

Operator Control Station & Safety

- Programmable Logic Controller with user-friendly operator Interface has Operator Screens with Diagnostic features, improved through continuous feedback from Press users.
- Compliance with CE/OHSA Safety regulations provided on demand.
- Air Reservoir provided with Safety Valve and Drain Cock.



Motorised Grease Lubrication

- Automatic Grease Lubrication system lubricates Crank Shaft Bushes, Connecting Rod Bushes and Slide Guides.
- Oil Sump Lubrication for Main Gear Train for effective lubrication and heat dissipation.
- Lubrication is monitored through Progressive Lubrication Supply Line to give fault signals on HMI screen.

Oil dipped Pitman Screw

- Slide adjustment threads oil dipped to reduce friction.
- Prevents jamming and increases life.



Pneumatic Die Cushion

- Piston type Pneumatic Die Cushion ensures Long life. It is Maintenance friendly and easy to remove & install.
- Hardened grounded saddles on Die Cushion Pad area to ensure enhanced life and accuracy.

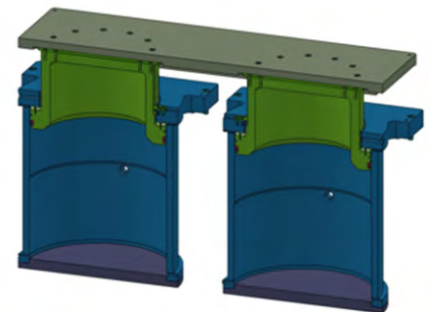

Standard Accessories

- Pneumatic Counter Balance Cylinders
- Hydraulic Overload Protection
- Motorized Slide Adjustment
- Automatic Forced Lubrication
- Operator Panel with PLC & HMI
- Pneumatic Clutch & Brake
- Emergency Stop Buttons
- Digital Shut Height Indicator
- Two Hand Push Button Station
- Production Counter
- Anti-Repeat Safety Device
- Rotary Cam Limit Switches
- Die Area Light
- Power Socket
- Photo Electric Guards

Optional Accessories

- Pneumatic Die Cushion
- Wet Clutch
- Variable Speed through AC Inverter
- Tonnage Monitor
- Quick Die Change System
- Anti Vibration Mounts
- Feedline Equipment (De-Coiler, Straightener, Feeder)
- Mis Feed Detection Socket
- Metallic Guards & Covers
- Safety Block
- Automated Component Transfer System (ACTS)
- Digital Crank Angle Indicator
- Programmable Soft Cams (8 Nos.)

Technical Specifications

Description	Unit	110T	160T	200T	250T	315T
Maximum Capacity	(kN)	1100	1600	2000	2500	3150
Rated Distance	(mm)	5	6	7	7	8
Suspension Points	(mm)	2	2	2	2	2
Speed (Fixed)	(spm)	60	45	45	40	40
Speed (Variable)	(spm)	40-80	30-60	30-60	30-50	25-50
Stroke Length (Fixed)	(spm)	110	130	180	250	250
Shut Height (SDAU)	(mm)	350	500	500/600	600	600
Slide Adjustment (Motorized)	(mm)	100	120	120	120	120
Slide Size (LR X FB)	(mm)	1500 x 500	1650 x 600	2100 x 700	2100 x 800	2100 x 800
Bolster Size (LR X FB)	(mm)	1800 x 700	2100 x 850	2400 x 900	2700 x 1050	2700 x 1050
Main Motor Power	(kW)	11	15	15	18.5	22
Die Cushion Capacity	(kN)	110	160	200	250	280
Stroke Length (Fixed)	(mm)	55	65	90	125	125
Die Cushion Area (LR X FB)	(mm)	1000 x 310	1100 x 450	1200 x 450	1450 x 650	1450 x 650

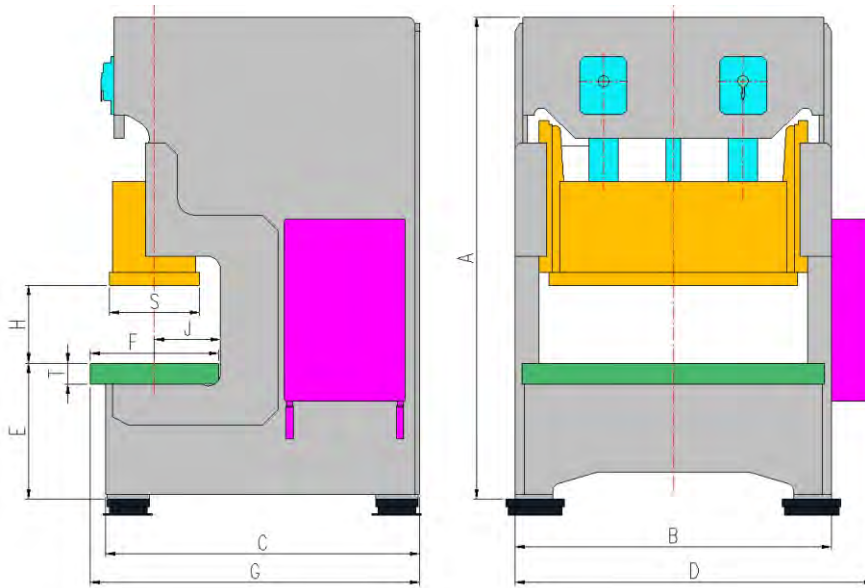

Model No.	A	B	C	D	E	F	G	H	J	S	T
G2-110T	2850	1975	1985	2255	900	680	2085	350	320	520	115
G2-160T	3185	2095	2080	2375	900	850	2180	500	430	600	140
G2-200T	3550	2350	2300	2600	1000	950	2300	550	480	700	150
G2-250T	4075	2640	2590	2895	1100	1050	2660	530	530	800	160
G2-315T	4500	3000	2950	3350	1150	1150	3075	600	600	900	160

Wide Range of Presses

Servo Presses • Transfer Presses • Progressive Presses • High Speed Presses • Hot Stamping & Hot Forming Hydraulic Presses
 Standard Straight Sided Mechanical & Hydraulic Presses • Blanking Lines • Tandem Press Lines - Mechanical & Hydraulic
 Cold Forging Presses • Tryout & Die Spotting Presses • Gap Frame & Ring Frame Power Presses • Special Purpose Presses



**ISGEC HEAVY
ENGINEERING LTD.**

www.isgpec.com



Follow us on:



Plant : Plot No. 123, Sector - 6, HSIIDC Growth Centre, Bawal - 123 501 (Haryana) India
 Tel.: +91-8930234025
 E-mail: smpbawal@isgpec.com, brijender@isgpec.com

Sales Office: **Gurgaon**
 Unit No. 0705, (7th Floor), Emerald Plaza, Sector-65, Gurugram - 122 102 (Haryana) India
 Tel.: +91-0124-405 2749 E-mail: smp.north@isgpec.com

Regional Offices: **Mumbai**
 Great Social Building, Sir Phirozshah Mehta Road, Fort, Mumbai 400 001, India
 Tel.: +91-22-22 66 23 74 Email: presses.wr@isgpec.com

Chennai
 Grace Building, (3rd Floor), No 25, Mc Nichols Road, Chetpet, Chennai 600 031, India
 Tel.: +91-44-28 36 13 75, 28 36 13 51 Email: presses.sr@isgpec.com

Kolkata
 18, Main Road, Kalianiwas, Barrackpore, Kolkata 700 122, India
 Tel.: +91-98363 61411 E-mail: presses.er@isgpec.com

Overseas Offices : Chonburi, Thailand • Windsor (Ontario), Canada • Portland (Tennessee), USA

Sales Representatives : Brazil • China • France • Germany • Hungary • Indonesia • Italy • Japan • Malaysia • Mexico
 Poland • Russia • South Africa • Spain • Thailand • Turkey • USA • Vietnam

*Some of the accessories / fitments shown in the reference photograph may not be part of Standard equipment supplied.
 Isgpec reserves the right to change specifications without prior notice.
 Details given in this Brochure are indicative & may change.*