



PRESSES

MECHANICAL • HYDRAULIC • SERVO

*Tandem Line
Mechanical Presses*

MAT Series

315T - 2000T



Safeties conform to:
CE (EN-16092 : 2018)
OSHA 1910.217
CSA-Z142
NR-12

ISO 9001:2015
ISO 14001:2015
OHSAS 18001 :2007

Presses for Tandem Stamping Operation

Side Moving Bolsters • Longer Stroke Length • Inter Press Transfer Automation

Tandem Operations & Inter Press Transfer

Presses with 'Long Stroke Length' and 'Open Uprights' for movement of Moving Bolsters on sides, are compatible for interfacing with Inter-Press Automation equipment for higher productivity requirements in Tandem Pressing operations :

- De-Stacker.
- Washer / Lubricator.
- Loading & Unloading Automation by Robotics, Pick & Place Devices, Swing type High Speed Transfer or Cross Bar Transfer Systems.
- End of the Line Conveyor.

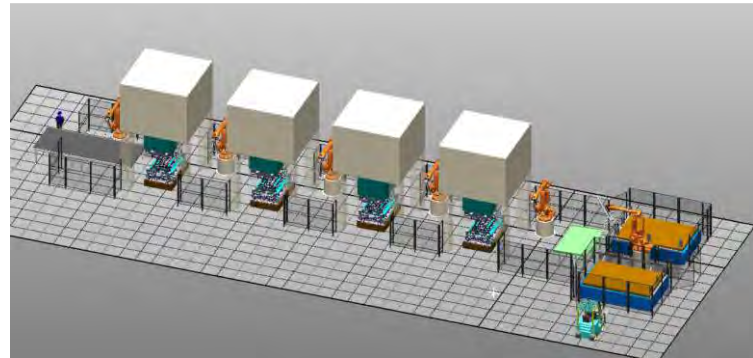

Permissible eccentric load (Mechanical Press)

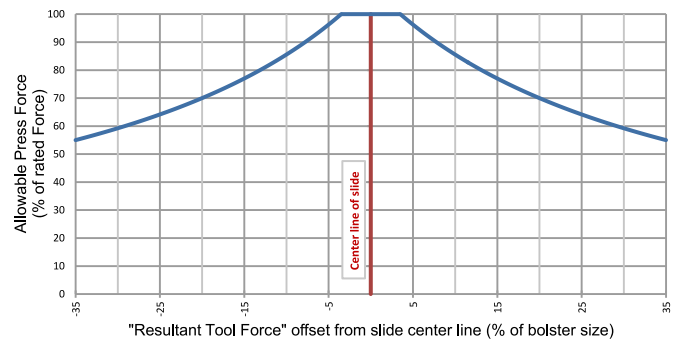

Efficient Drawing with Link Drive Motion

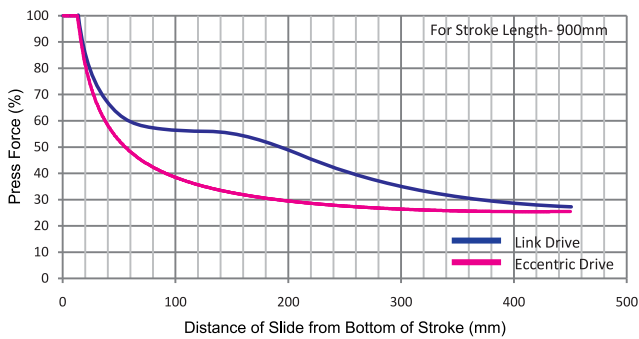

- Link Drive mechanism permits to work at low and constant speed during draw zone and at higher speed during idle (return) zone to improve quality of parts with higher productivity.
- In draw operations required on Head Press, Link Drive is particularly beneficial to reduce rejections & noise besides enhancing Die life.
- In Isgec design of Link Drive Mechanism in-line configuration of links at BDC enables smooth continuous motion under load with low acceleration.

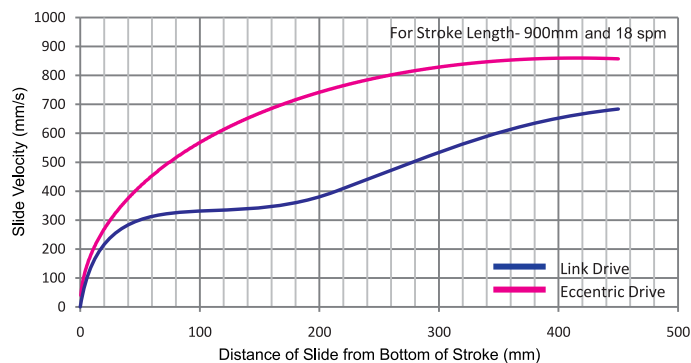

Accurate Stamping from High Rigidity

- Finite Element Analysis (FEA) software is adopted to verify fatigue life of Press Structure and to enable required maximised rigidity.
- Structure is fabricated from tested Steel Plates and thermally stress relieved.
- Enhanced Die life from low deflection of bolster.

Longer Stroke Facilitates Automation

- Drive mechanism ensures zero side thrust to achieve stability and long life with least maintenance of drive members.
- In such a drive, even in longer stroke length, plunger guiding is not required. Its advantage is, it avoids adverse affect of worn-out Plunger Guides under eccentric loading which cannot be compensated by any means.
- Precision Machined Gear Train of drive mechanism conforming to International Standards, produced on in house World Class Gear Hobbing & grinding machines, enable a smooth torque transmission.

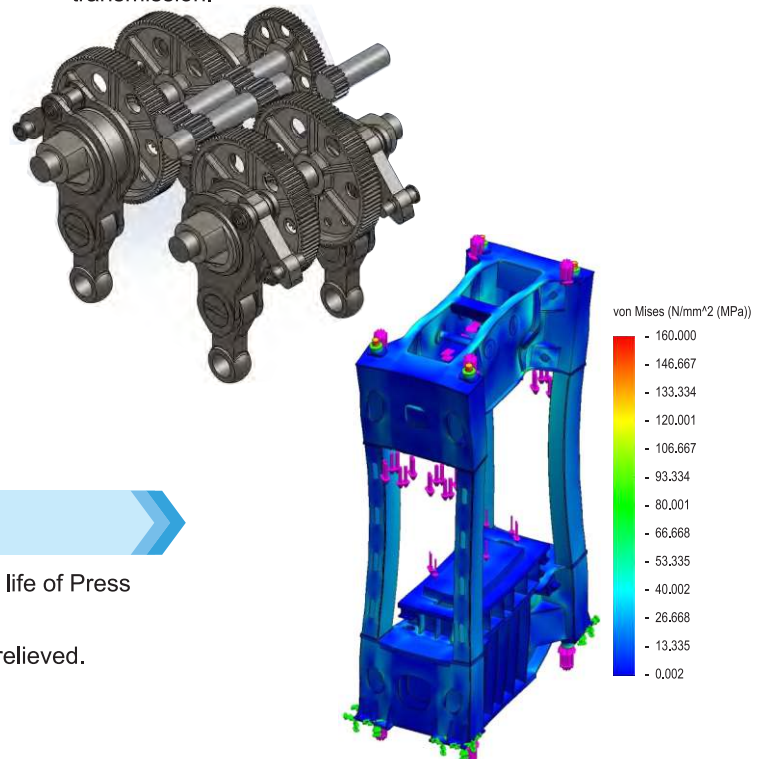



Quick Die Change System

- Electrically driven Moving Bolsters with alternative options of direction of movement for Quick Die Change and higher productivity.
- Die Centering Slots on Bolster Plate for quick die location in the Center of the Press.
- T-Slots, Cushion Pin Layout as per JIS, JIC & DIN depending upon user's requirement.
- Automatic or Semi Automatic Die Change feature available as option.
- On demand "Automatic" or "Hydraulically operated, Manually positioned" Die clamps provided.

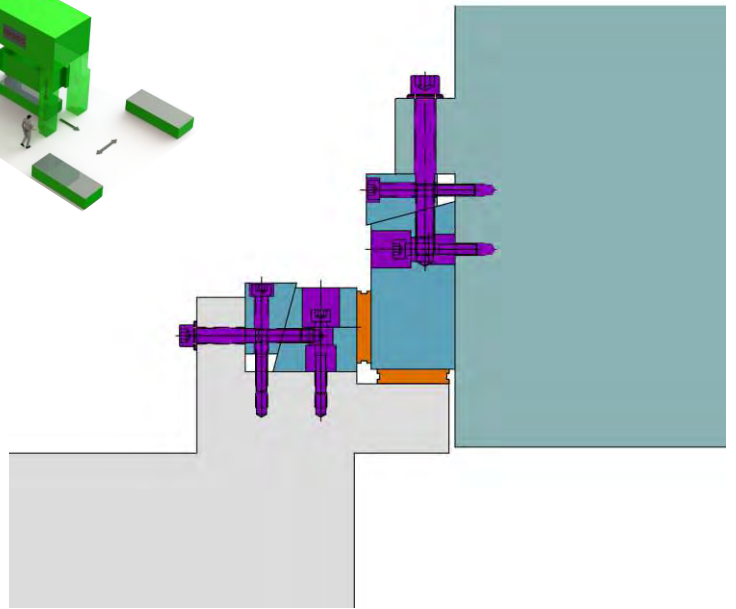
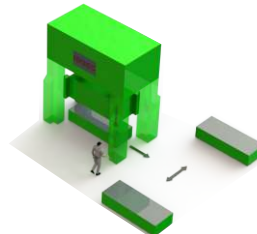
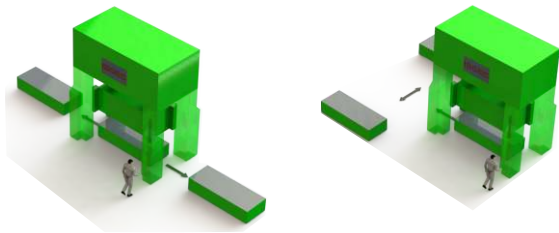

Sustained High Precision

- Precisely machined Eight (8) Face power adjusted Slide guiding keep the Slide fully guided, at all points of stroke and slide adjustment, for sustained accuracy & ease of maintenance.
- Widely spaced suspension points and extra-long gibs enables high eccentric load bearing capability.
- Press Geometrical accuracies (Parallelism, Perpendicularity & Flatness) confirming to JIS 6402 B Grade-I / DIN Standard for Eccentric Gear Drive Presses.

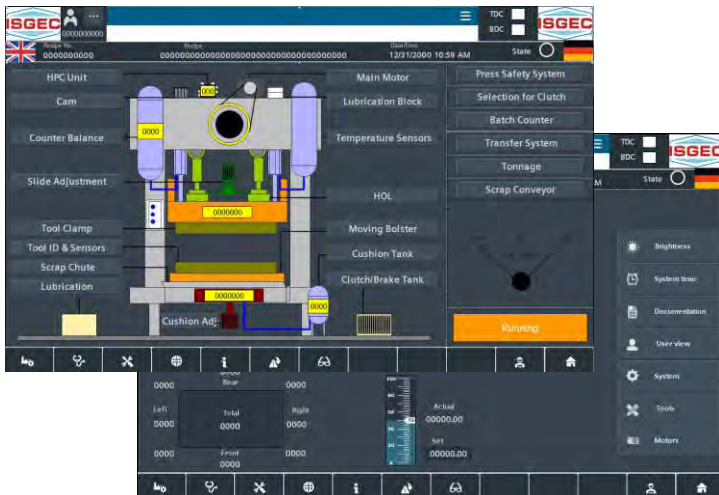

Ease of Operation & Interface

- Programmable Logic Controller with user friendly Operator Interface has operator Screens. HMI (Human Machine Interface) screens with Diagnostic features developed by constant improvements through feedback from Press users.
- On demand interfacing hardware for reliable interface with Automation.
- Remote online diagnosis feature provided on demand.
- Complete Project Management including Interface with Automation & Dies provided.

Quality Components

- | | | | |
|-------------------------------|--------------------------------------|-----------------------|--------------------------------------|
| • Clutch & Brake | : Ortlinghaus, OMPI, Goizper | • Cam Limit Switches: | Balluff, Kamco |
| • Electrical Drives | : Siemens, Allen Bradley, Mitsubishi | • Main Bearings | : SKF, FAG, INA, Timken |
| • Pneumatic Components | : SMC, Festo, Norgen, Legris | • PLC Controls | : Siemens, Allen Bradley, Mitsubishi |
| • Dual Solenoid Safety Valve: | Ortlinghaus, Ross, Herion, Toyooki | • Safety Relays | : Pilz, Safety PLC |
| • Lubrication | : Cenlub, Woerner, Trabon | • Main Motor | : Siemens/ABB, Havells |

* Other makes can also be used on specific demand



Technical Specifications

TWO POINT SUSPENSION ECCENTRIC DRIVE MECHANICAL PRESS – MAT-2E															
Model No.		MAT2E-315		MAT2E-400		MAT2E-500		MAT2E-630		MAT2E-800		MAT2E-1000		MAT2E-1250	
Maximum Capacity	kN	3150		4000		5000		6300		8000		10000		12500	
	US ton	347		440		550		693		880		1100		1375	
Rated Distance	mm	13		13		13		13		13		13		13	
	inch	0.5		0.5		0.5		0.5		0.5		0.5		0.5	
Strokes Per Minute (Variable)	SPM	12-24		12-24		12-24		12-24		12-24		12-24		12-24	
Strokes Per Minute (Intermittent)	SPM	12		12		12		12		12		12		12	
Available Work Energy Per stroke at Intermittent Strokes	kJ	80	95	120	130	150	165	200	220	240	260	330		400	
Stroke Length (Fixed)	mm	450	600	600	800	600	800	600	800	600	800	800		800	
	inch	17.7	23.6	23.6	31.5	23.6	31.5	23.6	31.5	23.6	31.5	31.5		31.5	
Shut Height (SDAU)	mm	800	1100	1100	1400	1100	1400	1100	1400	1100	1400	1100	1400	1100	1400
	inch	31.5	43.3	43.3	55.1	43.3	55.1	43.3	55.1	43.3	55.1	43.3	55.1	43.3	55.1
Slide Adjustment (Motorised)	mm	200	300	300	400	300	400	300	400	400		400		400	
	inch	7.9	11.8	11.8	15.7	11.8	15.7	11.8	15.7	15.7		15.7		15.7	
Slide & Bolster Face - LR X FB (Alt-1)	mm	2500x1600		2500x1600		2800x1600		2800x1600		3100x1600		3100x1900		3400x1900	
	inch	98.4x63.0		98.4x63.0		110.2x63.0		110.2x63.0		122.0x63.0		122.0x74.8		133.9x74.8	
Slide & Bolster Face - LR X FB (Alt-2)	mm	2800x1600		2800x1600		3100x1600		3100x1600		3400x1600		3400x1900		3700x1900	
	inch	110.2x63.0		110.2x63.0		122.0x63.0		122.0x63.0		133.9x63.0		133.9x74.8		145.7x74.8	
Slide & Bolster Face - LR X FB (Alt-3)	mm	3100x1600		3100x1600		3400x1600		3400x1600		3700x1600		3700x1900		4000x1900	
	inch	122.0x63.0		122.0x63.0		133.9x63.0		133.9x63.0		145.7x63.0		145.7x74.8		157.5x74.8	
Main Motor Power	kW	37		45		55		75		90		110		132	
	HP	50		60		75		100		120		150		180	
Die Cushion Capacity*	kN	500		630		800		1100		1250		1600		2000	
	US ton	55		69		88		121		138		176		220	
Die Cushion Stroke*	mm	160	220	220	250	220	250	220	250	220	250	250		250	
	inch	6.3	8.7	8.7	9.8	8.7	9.8	8.7	9.8	8.7	9.8	9.8		9.8	
Die Cushion Pad Size (Alt-1)	mm	2050x1150		2050x1150		2350x1150		2350x1150		2650x1150		2650x1450		2950x1450	
	inch	80.7 x 45.3		80.7 x 45.3		92.5 x 45.3		92.5 x 45.3		104.3 x 45.3		104.3 x 57.1		116.1 x 57.1	
Die Cushion Pad Size (Alt-2)	mm	2350x1150		2350x1150		2650x1150		2650x1150		2950x1150		2950x1450		3250x1450	
	inch	92.5 x 45.3		92.5 x 45.3		104.3 x 45.3		104.3 x 45.3		116.1 x 45.3		116.1 x 57.1		128 x 57.1	
Die Cushion Pad Size (Alt-3)	mm	2650x1150		2650x1150		2950x1150		2950x1150		3250x1150		3250x1450		3550x1450	
	inch	104.3x45.3		104.3x45.3		116.1x45.3		116.1x45.3		128x45.3		128x57.1		139.8x57.1	

TWO POINT SUSPENSION LINK DRIVE MECHANICAL PRESS – MAT-2L															
Model No.		MAT2L-315		MAT2L-400		MAT2L-500		MAT2L-630		MAT2L-800		MAT2L-1000		MAT2L-1250	
Maximum Capacity	kN	3150		4000		5000		6300		8000		10000		12500	
	US ton	347		440		550		693		880		1100		1375	
Rated Distance	mm	13		13		13		13		13		13		13	
	inch	0.5		0.5		0.5		0.5		0.5		0.5		0.5	
Strokes Per Minute (Variable)	SPM	12-24		12-24		12-24		12-24		12-24		12-24		12-24	
Strokes Per Minute (Intermittent)	SPM	12		12		12		12		12		12		12	
Available Work Energy Per stroke at Intermittent Strokes	kJ	80	95	120	130	150	165	225		270		330		400	
Stroke Length (Fixed)	mm	600	700	700	800	700	800	900		900		900		900	
	inch	23.6	27.6	27.6	31.5	27.6	31.5	35.4		35.4		35.4		35.4	
Shut Height (SDAU)	mm	800	1100	1100	1400	1100	1400	1100	1400	1100	1400	1100	1400	1100	1400
	inch	31.5	43.3	43.3	55.1	43.3	55.1	43.3	55.1	43.3	55.1	43.3	55.1	43.3	55.1
Slide Adjustment (Motorised)	mm	200	300	300	400	300	400	300	400	400		400		400	
	inch	7.9	11.8	11.8	15.7	11.8	15.7	11.8	15.7	15.7		15.7		15.7	
Slide & Bolster Face - LR X FB (Alt-1)	mm	2500x1600		2500x1600		2800x1600		2800x1600		3100x1600		3100x1900		3400x1900	
	inch	98.4x63.0		98.4x63.0		110.2x63.0		110.2x63.0		122.0x63.0		122.0x74.8		133.9x74.8	
Slide & Bolster Face - LR X FB (Alt-2)	mm	2800x1600		2800x1600		3100x1600		3100x1600		3400x1600		3400x1900		3700x1900	
	inch	110.2x63.0		110.2x63.0		122.0x63.0		122.0x63.0		133.9x63.0		133.9x74.8		145.7x74.8	
Slide & Bolster Face - LR X FB (Alt-3)	mm	3100x1600		3100x1600		3400x1600		3400x1600		3700x1600		3700x1900		4000x1900	
	inch	122.0x63.0		122.0x63.0		133.9x63.0		133.9x63.0		145.7x63.0		145.7x74.8		157.5x74.8	
Main Motor Power	kW	37		45		55		75		90		110		132	
	HP	50		60		75		100		120		150		180	
Die Cushion Capacity*	kN	500		630		800		1100		1250		1600		2000	
	US ton	55		69		88		121		138		176		220	
Die Cushion Stroke*	mm	180	220	220	250	220	250	280		280		280		280	
	inch	7.1	8.7	8.7	9.8	8.7	9.8	11.0		11.0		11.0		11.0	
Die Cushion Pad Size (Alt-1)	mm	2050x1150		2050x1150		2350x1150		2350x1150		2650x1150		2650x1450		2950x1450	
	inch	80.7x45.3		80.7x45.3		92.5x45.3		92.5x45.3		104.3x45.3		104.3x57.1		116.1x57.1	
Die Cushion Pad Size (Alt-2)	mm	2350x1150		2350x1150		2650x1150		2650x1150		2950x1150		2950x1450		3250x1450	
	inch	92.5x45.3		92.5x45.3		104.3x45.3		104.3x45.3		116.1x45.3		116.1x57.1		128x57.1	
Die Cushion Pad Size (Alt-3)	mm	2650x1150		2650x1150		2950x1150		2950x1150		3250x1150		3250x1450		3550x1450	
	inch	104.3x45.3		104.3x45.3		116.1x45.3		116.1x45.3		128x45.3		128x57.1		139.8x57.1	

Machines are manufactured as per SI Units. Dimensions in FPS are approximate and given only for reference. Customised Solutions can be offered on Demand.

* Optional Features



Technical Specifications

FOUR POINT SUSPENSION ECCENTRIC DRIVE MECHANICAL PRESS – MAT-4E																			
Model No.	MAT4E-315		MAT4E-400		MAT4E-500		MAT4E-630		MAT4E-800		MAT4E-1000		MAT4E-1250		MAT4E-1600		MAT4E-2000		
Maximum Capacity	kN	3150		4000		5000		6300		8000		10000		12500		16000		20000	
	US ton	347		440		550		693		880		1100		1375		1760		2200	
Rated Distance	mm	13		13		13		13		13		13		13		13		13	
	inch	0.5		0.5		0.5		0.5		0.5		0.5		0.5		0.5		0.5	
Strokes Per Minute (Variable)	SPM	12-24		12-24		12-24		12-24		12-24		12-24		12-24		12-24		12-24	
Strokes Per Minute (Intermittent)	SPM	12		12		12		12		12		12		12		12		12	
Available Work Energy Per stroke at Intermittent Strokes	kJ	80	95	120	130	150	165	220		260		330		400		540		700	
		mm	450	600	600	800	600	800	800		800		800		800		800		800
Stroke Length (Fixed)	mm	450	600	600	800	600	800	800		800		800		800		800		800	
	inch	17.7	23.6	23.6	31.5	23.6	31.5	31.5		31.5		31.5		31.5		31.5		31.5	
Shut Height (SDAU)	mm	800	1100	1100	1400	1100	1400	1100	1400	1100	1400	1100	1400	1100	1400	1100	1500	1100	1500
	inch	31.5	43.3	43.3	55.1	43.3	55.1	43.3	55.1	43.3	55.1	43.3	55.1	43.3	55.1	43.3	59.1	43.3	59.1
Slide Adjustment (Motorised)	mm	200	300	300	400	300	400	300	400	400	400	400	400	400	400	400	400	400	400
	inch	7.9	11.8	11.8	15.7	11.8	15.7	11.8	15.7	15.7	15.7	15.7	15.7	15.7	15.7	15.7	15.7	15.7	15.7
Slide & Bolster Face- LR X FB (Alt-1)	mm	2800x1900		2800x1900		2800x1900		2800x1900		3400x1900		3400x2200		3700x2200		4000x2500		4000x2500	
	inch	110.2x74.8		110.2x74.8		110.2x74.8		110.2x74.8		133.9x74.8		133.9x86.6		145.7x86.6		157.5x98.4		157.5x98.4	
Slide & Bolster Face - LR X FB (Alt-2)	mm	3100x1900		3100x1900		3100x1900		3100x1900		3700x2200		3700x2200		4000x2500		4300x2500		4300x2500	
	inch	122.0x74.8		122.0x74.8		122.0x74.8		122.0x74.8		145.7x86.6		145.7x86.6		157.5x98.4		169.3x98.4		169.3x98.4	
Slide & Bolster Face - LR X FB (Alt-3)	mm	3400x1900		3400x1900		3400x1900		3400x1900		4000x2500		4000x2500		4300x2500		4600x2500		4600x2500	
	inch	133.9x74.8		133.9x74.8		133.9x74.8		133.9x74.8		157.5x98.4		157.5x98.4		169.3x98.4		181.1x98.4		181.1x98.4	
Main Motor Power	kW	37		45		55		75		90		110		132		160		200	
	HP	50		60		75		100		120		150		180		215		270	
Die Cushion Capacity*	kN	500		630		800		1100		1250		1600		2000		3000		3000	
	US ton	55		69		88		121		138		176		220		330		330	
Die Cushion Stroke*	mm	160	220	220	250	220	250	250		250		280		280		300		300	
	inch	6.3	8.7	8.7	9.8	8.7	9.8	9.8		9.8		11.0		11.0		11.8		11.8	
Die Cushion Pad Size (Alt-1)	mm	2350x1450		2350x1450		2350x1450		2350x1450		2950x1450		2950x1750		3250x1750		3250x1750		3250x1750	
	inch	92.5x57.1		92.5x57.1		92.5x57.1		92.5x57.1		116.1x57.1		116.1x68.9		128.0x68.9		128.0x68.9		128.0x68.9	
Die Cushion Pad Size (Alt-2)	mm	2650x1450		2650x1450		2650x1450		2650x1450		3250x1750		3250x1750		3250x1750		3250x1750		3250x1750	
	inch	104.3x57.1		104.3x57.1		104.3x57.1		104.3x57.1		128.0x68.9		128.0x68.9		128.0x68.9		128.0x68.9		128.0x68.9	
Die Cushion Pad Size (Alt-3)	mm	2950x1450		2950x1450		2950x1450		2950x1450		3250x1750		3250x1750		3250x1750		3550x1750		3550x1750	
	inch	116.1x57.1		116.1x57.1		116.1x57.1		116.1x57.1		128.0x68.9		128.0x68.9		128.0x68.9		139.8x68.9		139.8x68.9	

FOUR POINT SUSPENSION LINK DRIVE MECHANICAL PRESS – MAT-4L																			
Model No.	MAT4L-315		MAT4L-400		MAT4L-500		MAT4L-630		MAT4L-800		MAT4L-1000		MAT4L-1250		MAT4L-1600		MAT4L-2000		
Maximum Capacity	kN	3150		4000		5000		6300		8000		10000		12500		16000		20000	
	US ton	347		440		550		693		880		1100		1375		1760		2200	
Rated Distance	mm	13		13		13		13		13		13		13		13		13	
	inch	0.5		0.5		0.5		0.5		0.5		0.5		0.5		0.5		0.5	
Strokes Per Minute (Variable)	SPM	12-24		12-24		12-24		12-24		12-24		12-24		12-24		12-24		12-24	
Strokes Per Minute (Intermittent)	SPM	12		12		12		12		12		12		12		12		12	
Available Work Energy Per stroke at Intermittent Strokes	kJ	80	95	120	130	150	165	225		270		330		400		540		700	
		mm	600	700	700	800	700	800	900		900		900		1000		1000		
Stroke Length (Fixed)	mm	600	700	700	800	700	800	900		900		900		1000		1000			
	inch	23.6	27.6	27.6	31.5	27.6	31.5	35.4		35.4		35.4		39.4		39.4			
Shut Height (SDAU)	mm	800	1100	1100	1400	1100	1400	1100	1400	1100	1400	1100	1400	1100	1500	1100	1500		
	inch	31.5	43.3	43.3	55.1	43.3	55.1	43.3	55.1	43.3	55.1	43.3	55.1	43.3	59.1	43.3	59.1		
Slide Adjustment (Motorised)	mm	200	300	300	400	300	400	300	400	400	400	400	400	400	400	400	400		
	inch	7.9	11.8	11.8	15.7	11.8	15.7	11.8	15.7	15.7	15.7	15.7	15.7	15.7	15.7	15.7	15.7		
Slide & Bolster Face- LR X FB (Alt-1)	mm	2800x1900		2800x1900		2800x1900		2800x1900		3400x1900		3400x2200		3700x2200		4000x2500		4000x2500	
	inch	110.2x74.8		110.2x74.8		110.2x74.8		110.2x74.8		133.9x74.8		133.9x86.6		145.7x86.6		157.5x98.4		157.5x98.4	
Slide & Bolster Face- LR X FB (Alt-2)	mm	3100x1900		3100x1900		3100x1900		3100x1900		3700x2200		3700x2200		4000x2500		4300x2500		4300x2500	
	inch	122.0x74.8		122.0x74.8		122.0x74.8		122.0x74.8		145.7x86.6		145.7x86.6		157.5x98.4		169.3x98.4		169.3x98.4	
Slide & Bolster Face- LR X FB (Alt-3)	mm	3400x1900		3400x1900		3400x1900		3400x1900		4000x2500		4000x2500		4300x2500		4600x2500		4600x2500	
	inch	133.9x74.8		133.9x74.8		133.9x74.8		133.9x74.8		157.5x98.4		157.5x98.4		169.3x98.4		181.1x98.4		181.1x98.4	
Main Motor Power	kW	37		45		55		75		90		110		132		160		200	
	HP	50		60		75		100		120		150		180		215		270	
Die Cushion Capacity*	kN	500		630		800		1100		1250		1600		2000		3000		3000	
	US ton	55		69		88		121		138		176		220		330		330	
Die Cushion Stroke*	mm	180	220	220	250	220	250	280		280		280		300		300			
	inch	7.1	8.7	8.7	9.8	8.7	9.8	11.0		11.0		11.0		11.8		11.8			
Die Cushion Pad Size (Alt-1)	mm	2350x1450		2350x1450		2350x1450		2350x1450		2950x1450		2950x1750		3250x1750		3250x1750		3250x1750	
	inch	92.5x57.1		92.5x57.1		92.5x57.1		92.5x57.1		116.1x57.1		116.1x68.9		128.0x68.9		128.0x68.9		128.0x68.9	
Die Cushion Pad Size (Alt-2)	mm	2650x1450		2650x1450		2650x1450		2650x1450		3250x1750		3250x1750		3250x1750		3250x1750		3250x1750	
	inch	104.3x57.1		104.3x57.1		104.3x57.1		104.3x57.1		128.0x68.9		128.0x68.9		128.0x68.9		128.0x68.9		128.0x68.9	
Die Cushion Pad Size (Alt-3)	mm	2950x1450		2950x1450		2950x1450		2950x1450		3250x1750		3250x1750		3250x1750		3550x1750		3550x1750	
	inch	116.1x57.1		116.1x57.1		116.1x57.1		116.1x57.1		128.0x68.9		128.0x68.9		128.0x68.9		139.8x68.9		139.8x68.9	

Machines are manufactured as per SI Units. Dimensions in FPS are approximate and given only for reference. Customised Solutions can be offered on Demand.

* Optional Features

Standard Accessories

- Programmable Logic Controller
- Dual Check Safety Electrical Circuit
- Production Counters (Total Batch/Shift)
- High Response Hydraulic Overload System
- Variable Speed through AC Inverter
- Motorised Slide Adjustment
- Centralised Re-circulating Automatic Oil Lubrication System
- User Friendly Touch Screen Interface
- Hydraulic Clutch & Brake
- Emergency Stop Buttons
- Moving Bolsters (Center to Left/Right Movement)
- LED Die Area lights
- Mechanical Safety Guard on sides
- Portable Two Hand Operator Stand
- Safety Blocks with Interlocks
- Digital Crank Angle Indicators (Display on HMI)
- Maintenance Platform & Ladder
- Photoelectric Guards on front and rear
- Main Motor Forward Reverse Facility
- Programmable Cam Switches

Optional Accessories

- Die Clamps for Quick Die Change
- Die Cushion
- Die Cushion with Stroke Adjustment
- Die Cushion Pin Lifting in Moving Bolster
- Electronic Force Monitoring / Process Monitoring with Signature Analysis
- Anti Vibration Mounts
- Scrap Chute with Interlocked opening covers
- Noise & Dust Enclosure
- Wet/Pneumatic Clutch & Brake
- Compliance with CE/OSHA Safety Standards
- Robotic / High Speed Automation System
- Plunger Guiding
- Automatic Die Change System
- Slide Locking Device
- Temperature Monitoring System
- Moving Bolster with T-Track on selected models
- Die Automation Control
- Isgec Reach 4.0 enabled Smart Control

We Supply & Integrate the Press Line with ABB, KUKA, Yaskawa, FANUC, Comau, Güdel, Linear, Norda or any Customer recommended make Transfer & Automation System

Wide Range of Presses

Servo Presses • Transfer Presses • Progressive Presses • High Speed Presses • Hot Stamping & Hot Forming Hydraulic Presses
Standard Straight Sided Mechanical & Hydraulic Presses • Blanking Lines • Tandem Press Lines - Mechanical & Hydraulic
Cold Forging Presses • Tryout & Die Spotting Presses • Gap Frame & Ring Frame Power Presses • Special Purpose Presses



India



Canada

www.isgec.com



Follow us on:



Sales Offices & Plants :

Isgec Heavy Engineering Ltd.
Yamunanagar - 135 001 (Haryana) India
Tel.: +91-1732-661 104, 661 140
E-mail: presses@isgec.com

Bawal - 123 501 (Haryana) India
Tel.: +91-1284-302160
E-mail: smpbawal@isgec.com

Eagle Press & Equipment Co. Ltd.
Windsor (Ontario) Canada

Regional Offices : Ahmedabad • Bengaluru • Chennai • Gurgaon • Kolkata • Mumbai • Noida • Pune

Overseas Offices : Chonburi, Thailand • Ontario, Canada • Tennessee, USA

Corporate Office : Isgec Heavy Engineering Ltd.
A-4, Sector 24, Noida - 201 301 (U.P.) India
Tel.: +91-120-408 50 01 / 02

Sales Representatives : Brazil • China • France • Germany • Hungary • Indonesia • Italy • Japan
Malaysia • Mexico • Poland • Russia • South Africa • Spain • Thailand
Turkey • USA • Vietnam

*Some of the accessories / fitments shown in the reference photograph may not be part of Standard equipment supplied.
Isgec reserves the right to change specifications without prior notice.
Details given in this Brochure are indicative & may change.*