



PRESSES
MECHANICAL & HYDRAULIC

Straight Sided Double Crank Mechanical Presses

MAX 2 Series
200T - 630T



Safeties Conform to:

CE (EN-692)
OSHA 1910.217
CSA Z142-10
NR-12

ISO 9001:2008
ISO 14001:2004
OHSAS 18001 :2007

Cost Effective Stamping Solution

Ideal for Progressive Operations • Suitable for Forming, Punching & Blanking

Accurate Stampings & Enhanced Die Life • Prompt Local Service Support



Ideal for Progressive Operations



Wide side opening enables automated feeding of coil and blanks to produce long length & narrow width components through progressive feeding.



315 T MAX 2L Press supplied for Progressive Die Application

Eccentric Load Bearing Capacity

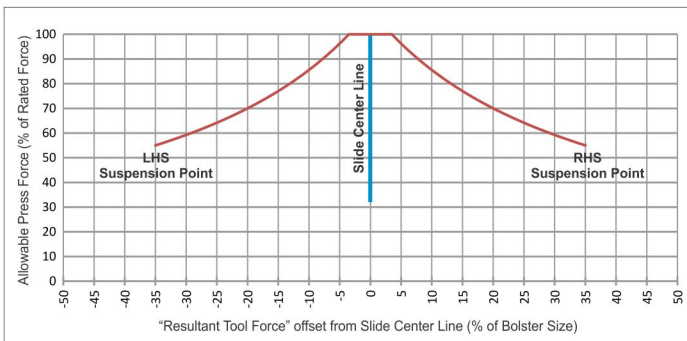

High eccentric load bearing capability due to wide space between suspension points, extra rigidity and long slide height helps in producing asymmetrical components.

Safety of Machine & Die

Hydraulically operated fast acting mechanism mounted under each suspension, senses the application of load beyond capacity of each suspension, and thereby prevents damage to Press and Die by quick stoppage.

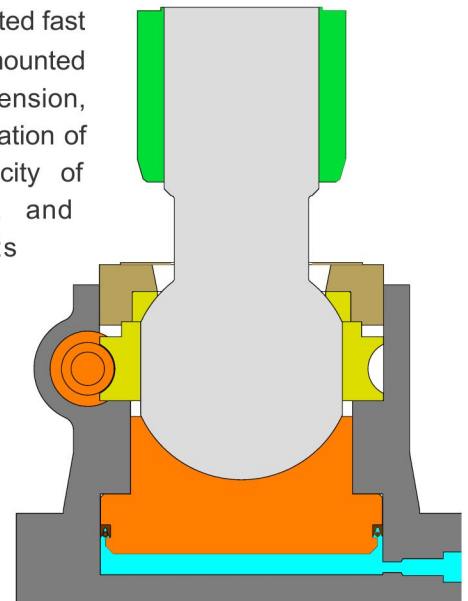

Precise and Vibration free Transmission



Crank Shaft

Forged from Normalized Alloy Carbon Steel, Ultrasonically Tested.

CAD analysis ensures elimination of stress concentrations and metal fatigues.

Gear

Gears of drive train machined to precision grade, conforming to DIN Grade 7 or AGMA 10 and better, for smooth torque transmission and vibration free operation.

Pinion

Forged Alloy Steel, Hardened & Tempered, Ultrasonically Tested, Accurately Machined and Ground.

Connecting Rod

Steel Casted, Normalized and Ultrasonically Tested.

Flywheel

Dynamically balanced Flywheel for long life of bearings.

Force vs Stroke Curve (MAX 2L)

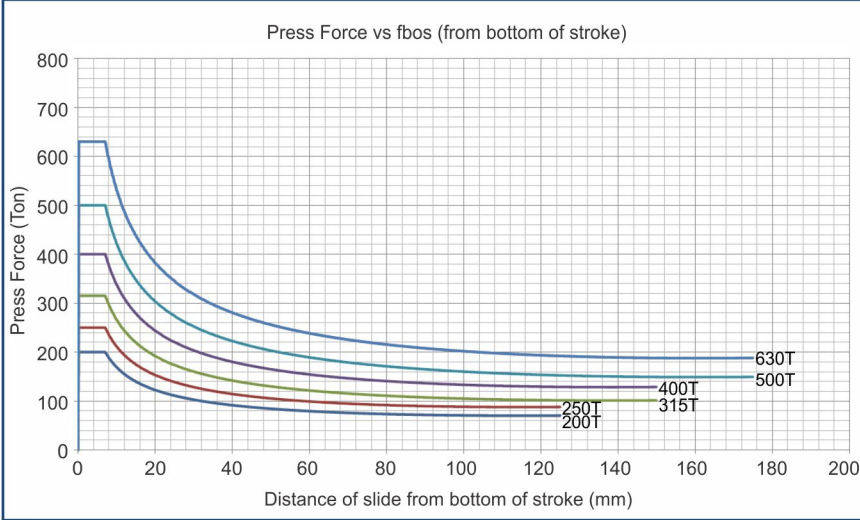

MAX 2L

- High Speed and Production
- Ideal for Coil feed and Progressive work

MAX 2H

- High Work Energy
- Enhanced Die Cushion Capacity
- Forming Capability
- Ideal for Transfer work

MAX2 Series Presses are easy to interface with various automation equipment like Transfer, Coil Feed Line etc.

Further, our experienced team can help you to select a press suitable for your stamping requirements and application.

Force vs. Stroke Curve (MAX 2H)

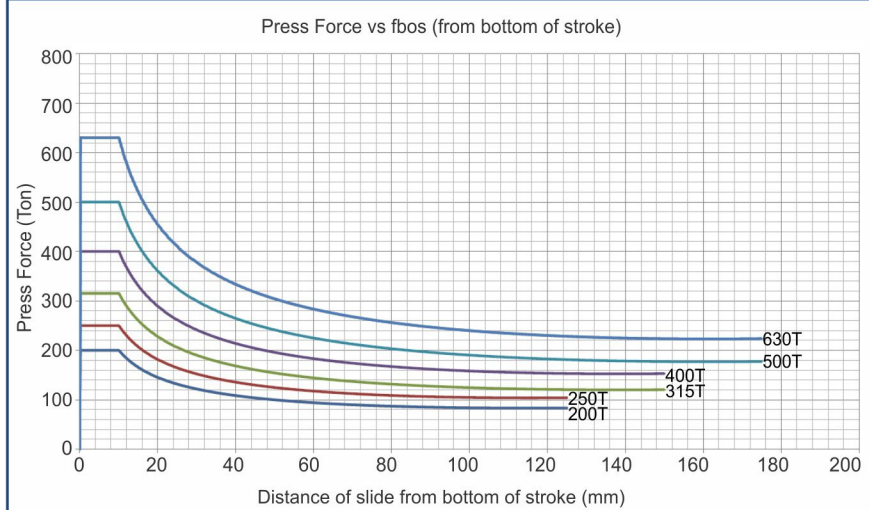

Velocity vs Stroke Curve

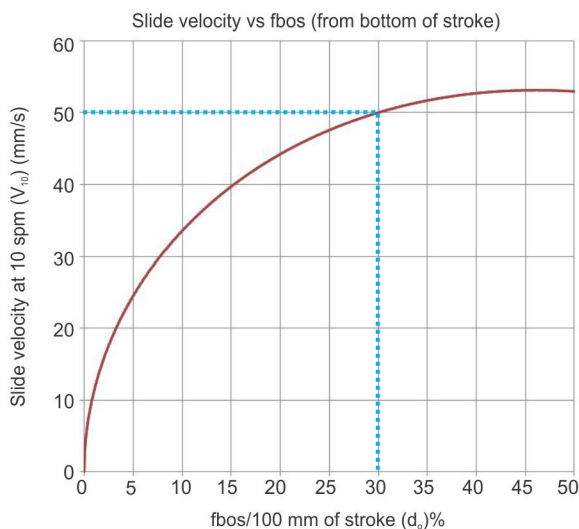

Slide Velocity Calculation

Machine SPM = R

Stroke Length = L (mm)

Distance fbos = d (mm)

V_d = Slide Velocity at distance fbos d (mm/s)

$d_0 = 100 \times d/L$ (%)

V_{10} = See chart according to d_0 (mm/s)

$V_d = V_{10} \times R \times L/1000$ (mm/s)

Example:

Machine SPM = 20

Stroke Length = 300

Distance fbos = 90 (mm)

V_d = Slide Velocity at distance fbos 90 (mm/s)

$d_0 = 100 \times 90/300 = 30$ (%)

V_{10} = See chart according to 30% = 50 (mm/s)

$V_d = V_{10} \times R \times L/1000 = 50 \times 20 \times 300/1000 = 300$ (mm/s)

High Precision

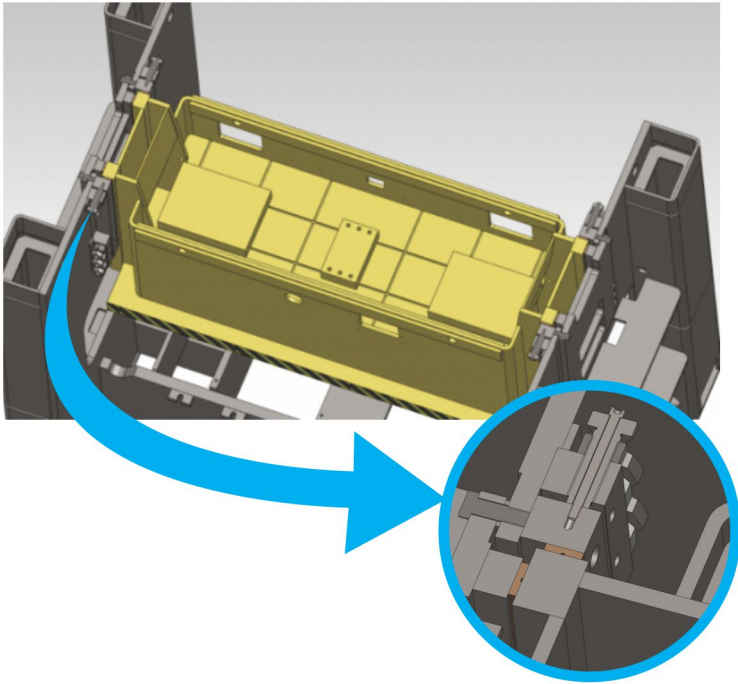

Precision machined 8 point extra long guide for precise Slide movement, conforming to JIS 6402 B Grade-I for geometrical accuracies.

High Rigidity

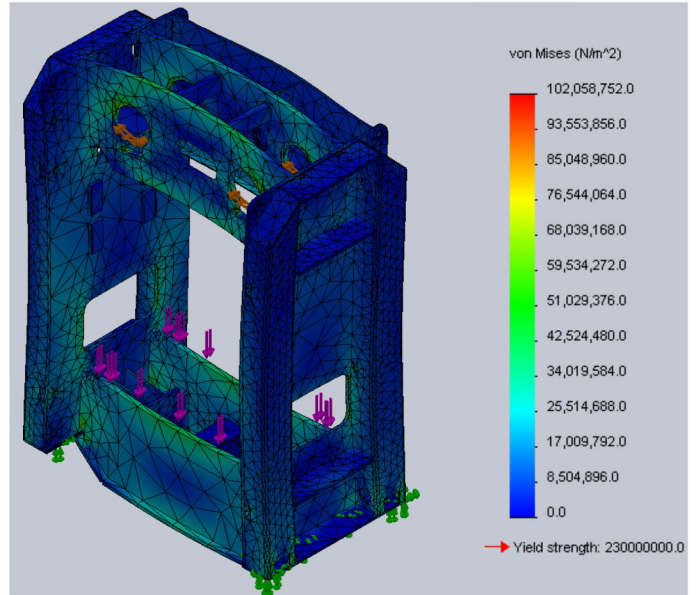

Frame & Slide fabricated from tested Steel Plates and stress relieved, to ensure fatigue-free long life of the frame.

Fatigue life of stress relieved Press structure verified using Finite Element Analysis to ensure maximum rigidity for accurate stampings & enhanced die life.

Safety of Operator



Press is equipped with dual safeties in control systems with monitoring of redundancies.

- Dual safety valve provided for Clutch and Brake actuation for dual redundancy of the system.
- Anti repeat circuit with dual circuit.
- Emergency stop buttons on panel and run button station.
- Two hand Run Button Station.
- Photoelectric Safety Guards (Optional).
- Compliance with CE/OSHA safety regulations provided on demand.



CE Safety Certificate

User Friendly Operator Interface

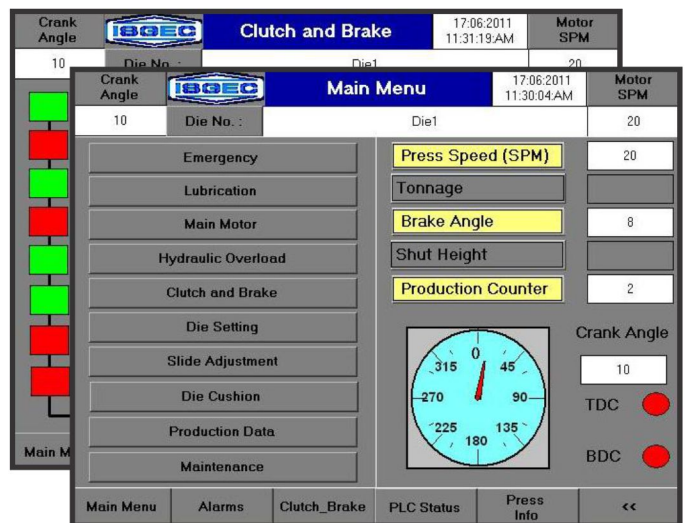

- Programmable Logic Controller with user friendly operator interface through HMI screens with Diagnostic feature.
- Ergonomically designed HMI Screens developed after practical feedback from the Press users.
- Screen Navigation with soft keys.
- Status & Alarm display for ease in operation.

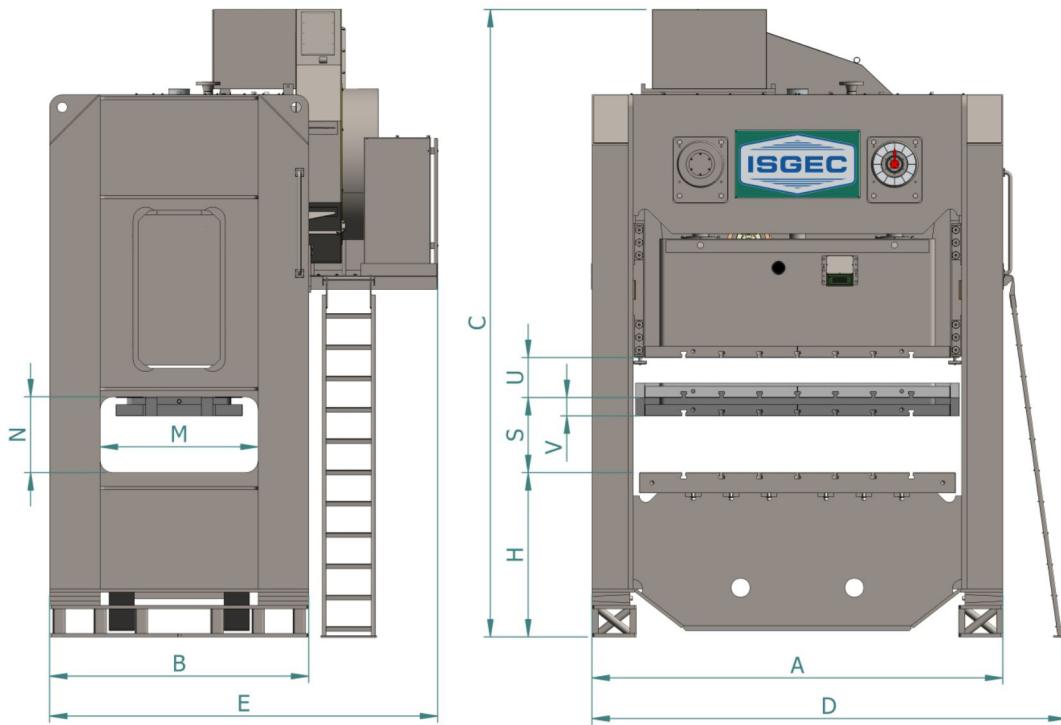

Technical Specifications

Description		Unit	200T		250T		315T		400T		500T		630T	
			MAX2L	MAX2H	MAX2L	MAX2H	MAX2L	MAX2H	MAX2L	MAX2H	MAX2L	MAX2H	MAX2L	MAX2H
Model No.			MAX2L	MAX2H	MAX2L	MAX2H	MAX2L	MAX2H	MAX2L	MAX2H	MAX2L	MAX2H	MAX2L	MAX2H
Maximum Capacity	kN		2000	2000	2500	2500	3150	3150	4000	4000	5000	5000	6300	6300
Rated Distance	mm		7	10	7	10	7	10	7	10	7	10	7	10
	inch		0.3	0.4	0.3	0.4	0.3	0.4	0.3	0.4	0.3	0.4	0.3	0.4
Strokes Per Minute (Fixed)	SPM		40	23	40	18	37	18	37	16	30	16	30	16
Strokes Per Minute (Variable)*	SPM		20-55	15-30	20-55	12-24	20-55	12-24	30-50	10-20	20-40	10-20	20-40	10-20
Strokes Per Minute (Intermittent)	SPM		20	12	16	9	14	9	12	8	12	8	12	8
Available Work Energy per stroke at continuous Mean SPM	kJ		19	32	22	45	32	56	37	76	60	92	74	106
Available Work Energy per stroke at Maximum Intermittent SPM	kJ		26	35	32	45	40	56	54	76	65	92	74	106
Stroke Length (Fixed) (U)	mm		250	250	250	250	300	300	300	300	350	350	350	350
	inch		9.8	9.8	9.8	9.8	11.8	11.8	11.8	11.8	13.8	13.8	13.8	13.8
Shut Height (SDAU) (S)	mm		550	550	550	550	800	800	800	800	1000	1000	1000	1000
	inch		21.7	21.7	21.7	21.7	31.5	31.5	31.5	31.5	39.4	39.4	39.4	39.4
Slide Adjustment (V)	mm		120	120	120	120	120	120	120	120	120	120	120	120
	inch		4.7	4.7	4.7	4.7	4.7	4.7	4.7	4.7	4.7	4.7	4.7	4.7
Slide Face- LR X FB (Alt-1)	mm		2200 x 820	2200 x 820	2200x1000	2200x1000	2200x1000	2200x1000	2500x1000	2500x1000	3100x1200	3100x1200	3100x1200	3100x1200
	inch		86.6x32.3	86.6x32.3	86.6x39.4	86.6x39.4	86.6x39.4	86.6x39.4	98.4x39.4	98.4x39.4	122x47.2	122x47.2	122x47.2	122x47.2
Slide Face- LR X FB (Alt-2)	mm		X	X	2500x1000	2500x1000	2500x1000	2500x1000	2800x1000	2800x1000	3400x1200	3400x1200	3400x1200	3400x1200
	inch		X	X	98.4x39.4	98.4x39.4	98.4x39.4	98.4x39.4	110.2x39.4	110.2x39.4	133.9x47.2	133.9x47.2	133.9x47.2	133.9x47.2
Slide Face- LR X FB (Alt-3)	mm		X	X	X	X	2800x1000	2800x1000	3100x1000	3100x1000	X	X	X	X
	inch		X	X	X	X	110.2x39.4	110.2x39.4	122x39.4	122x39.4	X	X	X	X
Bolster Size- LR X FB (Alt1)	mm		2500 x 920	2500 x 920	2500x1100	2500x1100	2500x1100	2500x1100	2800x1100	2800x1100	3400x1300	3400x1300	3400x1300	3400x1300
	inch		98.4x36.2	98.4x36.2	98.4x43.3	98.4x43.3	98.4x43.3	98.4x43.3	110.2x43.3	110.2x43.3	133.9x51.2	133.9x51.2	133.9x51.2	133.9x51.2
Bolster Size- LR X FB (Alt2)	mm		X	X	2800x1100	2800x1100	2800x1100	2800x1100	3100x1100	3100x1100	3700x1300	3700x1300	3700x1300	3700x1300
	inch		X	X	110.2x43.3	110.2x43.3	110.2x43.3	110.2x43.3	122x43.3	122x43.3	145.7x51.2	145.7x51.2	145.7x51.2	145.7x51.2
Bolster Size- LR X FB (Alt3)	mm		X	X	X	X	3100x1100	3100x1100	3400x1100	3400x1100	X	X	X	X
	inch		X	X	X	X	122x43.3	122x43.3	133.9x43.3	133.9x43.3	X	X	X	X
Side Opening (M x N)	mm		820 x 460	820 x 460	820x460	820x460	1000x550	1000x550	1000x550	1000x550	1200 x 700	1200 x 700	1200 x 700	1200 x 700
	inch		32.3x18.1	32.3x18.1	32.3x18.1	32.3x18.1	39.4x21.6	39.4x21.6	39.4x21.6	39.4x21.6	47.2x27.5	47.2x27.5	47.2x27.5	47.2x27.5
Main Motor Power	kW		18.5	18.5	22	22	30	30	37	37	45	45	55	55
	HP		25	25	30	30	40	40	50	50	60	60	75	75
Slide Adjustment Motor	kW		1.5	1.5	1.5	1.5	1.5	1.5	1.5	1.5	2.2	2.2	2.2	2.2
	HP		2	2	2	2	2	2	2	2	3	3	3	3
Die Cushion Capacity*	kN		160	200	200	280	200	280	280	400	280	400	280	400
Die Cushion Stroke*	mm		125	125	125	125	150	150	150	150	150	150	150	150
	inch		4.9	4.9	4.9	4.9	5.9	5.9	5.9	5.9	5.9	5.9	5.9	5.9
Die Cushion Pad Size*	mm		1600x650	1600x650	1600x700	1600x700	1600x700	1600x700	1600x700	1600x700	1600x700	1600x700	1600x700	1600x700
	inch		63x25.5	63x25.5	63x27.6	63x27.6	63x27.6	63x27.6	63x27.6	63x27.6	63x27.6	63x27.6	63x27.6	63x27.6
Working Height (H) (Press mounted on floor) (Approx.)	Alt.1	mm	1250	1250	1300	1300	1300	1300	1500	1500	1750	1750	2000	2000
	Alt.1	inch	49.2	49.2	51.2	51.2	51.2	51.2	59	59	68.9	68.9	78.7	78.7
	Alt.2	mm	X	X	1400	1400	1400	1400	1600	1600	1850	1850	2100	2100
	Alt.2	inch	X	X	55.1	55.1	55.1	55.1	63.0	63.0	72.8	72.8	82.7	82.7
Press Height with vibromounts (C) (Approx.)	Alt.3	mm	X	X	X	X	1500	1500	1700	1700	X	X	X	X
	Alt.3	inch	X	X	X	X	59.1	59.1	66.9	66.9	X	X	X	X
	Alt1	mm	5000	5000	5250	5250	5500	5500	5750	5750	6500	6500	7500	7500
	Alt1	inch	197	197	207	207	217	217	226	226	256	256	295	295
Foot Size (AxB) (Approx.)	Alt2	mm	X	X	5500	5500	5750	5750	6000	6000	6750	6750	7750	7750
	Alt2	inch	X	X	217	217	226	226	236	236	266	266	305	305
	Alt3	mm	X	X	X	X	6000	6000	6250	6250	X	X	X	X
	Alt3	inch	X	X	X	X	236	236	246	246	X	X	X	X
Required Floor space (DxE)(Approx.)	Alt.1	mm	3750x3500	3750x3500	3750x3500	3750x3500	3750x3500	3750x3500	4100x3500	4100x3500	4900x4000	4900x4000	5000x4000	5000x4000
	Alt.1	inch	147.6x137.8	147.6x137.8	147.6x137.8	147.6x137.8	147.6x137.8	147.6x137.8	161.4x137.8	161.4x137.8	192.9x157.5	192.9x157.5	196.9x157.5	196.9x157.5
	Alt.2	mm	X	X	4000x3500	4000x3500	4000x3500	4000x3500	4400x3500	4400x3500	5200x4000	5200x4000	5300x4000	5300x4000
	Alt.2	inch	X	X	157.5x137.8	157.5x137.8	157.5x137.8	157.5x137.8	173.2x137.8	173.2x137.8	204.7x157.5	204.7x157.5	208.7x157.5	208.7x157.5
Required Floor space (DxE)(Approx.)	Alt.3	mm	X	X	X	X	4350x3500	4350x3500	4700x3500	4700x3500	X	X	X	X
	Alt.3	inch	X	X	X	X	171.3x137.8	171.3x137.8	185.0x137.8	185.0x137.8	X	X	X	X

* Optional features
 # Single stroke working is recommended up to mid SPM only.
 Machines are manufactured as per SI Units. Dimensions in FPS are approximate and given only for reference.

Standard Accessories

- Pneumatic Counter Balance Cylinder
- Hydraulic Overload Protection
- Motorised Slide Adjustment
- Automatic Forced Lubrication
- Programmable Logic Control
- Pneumatic Clutch & Brake
- Emergency Stop buttons
- Die Height Indicator
- Portable Two Hand Operator Stand
- Production Counter
- Dual Safeties
- Die Area Light

Optional Accessories

- Pneumatic Die Cushion
- Tonnage Monitor
- Quick Die Change System
- Anti Vibration Mounts
- Interfacing provision with coil feeding system
- Variable Speed through AC Inverter
- Photo Electric Guards
- Mis-Feed Detection
- Safeties conform to CE/OSHA
- Die Protection System
- Mechanical Knock Out

MAX 2 Slide and Bolster Dimensions

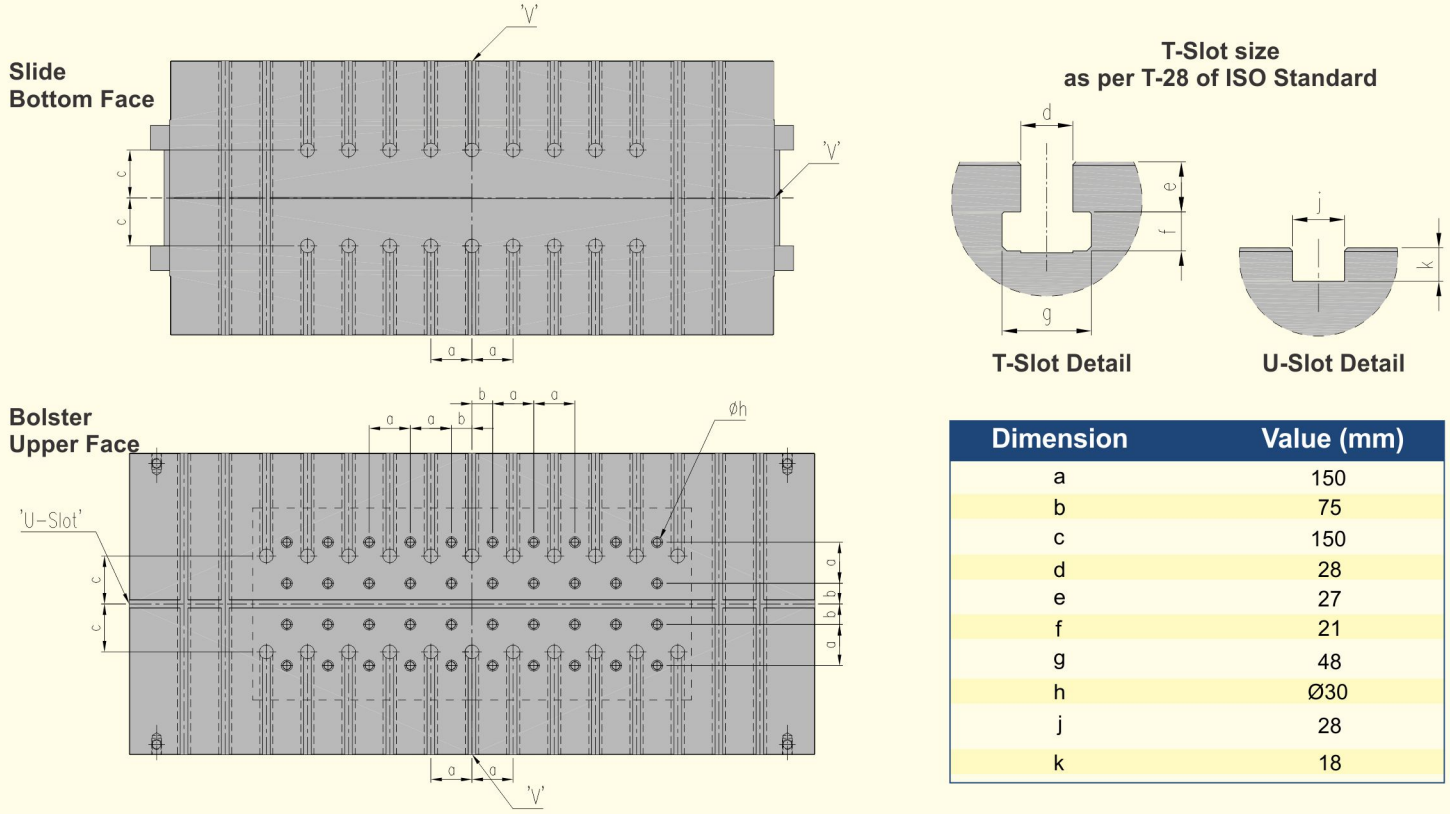

Wide Range of Presses

Servo Presses • Transfer Presses • Progressive Presses • High Speed Presses • Hot Stamping & Hot Forming Hydraulic Presses
 Standard Straight Sided Mechanical & Hydraulic Presses • Blanking Lines • Tandem Press Lines - Mechanical & Hydraulic
 Cold Forging Presses • Tryout & Die Spotting Presses • Gap Frame & Ring Frame Power Presses • Special Purpose Presses



**ISGEC HEAVY
ENGINEERING LTD.**

www.isgrec.com



Sales Office & Plant : Yamunanagar - 135 001, Haryana, India
 Tel.: +91-1732-66 11 14, 66 11 18 E-mail: presses@isgrec.com

Regional Offices: **Noida**
 A-4, Sector-24, Noida - 201 301, Uttar Pradesh, India
 Tel.: +91-120-408 5390 Email: presses@isgrec.com

Mumbai
 Great Social Building, Sir Phirozshah Mehta Road, Fort, Mumbai 400 001, India
 Tel.: +91-22-22 66 23 74 Email: presses.wr@isgrec.com

Chennai
 Grace Building, 3rd Floor, No.25, Mc Nichols Road, Chetpet, Chennai 600 031, India
 Tel.: +91-44-28 36 13 75 Email: presses.sr@isgrec.com

Kolkata
 18, Main Road, Kalianiwass, Barrackpore, Kolkata 700 122, India
 Tel.: +91-98363 61411 E-mail: presses.er@isgrec.com

Ahmedabad
 Tel.: +91-89301 11478 E-mail: presses.gr@isgrec.com

Bangalore
 Tel.: +91-89301 11654 E-mail: presses.br@isgrec.com

Overseas Offices : Ontario, Canada • Dusseldorf, Germany

Sales Representatives : Brazil • China • France • Hungary • Indonesia • Italy • Malaysia • Mexico
 Russia • South Africa • Spain • Thailand • Turkey • USA • Japan